

New Technology is Here!

QUANTUMTM
PARALLEL SHAFT FAN DRIVE

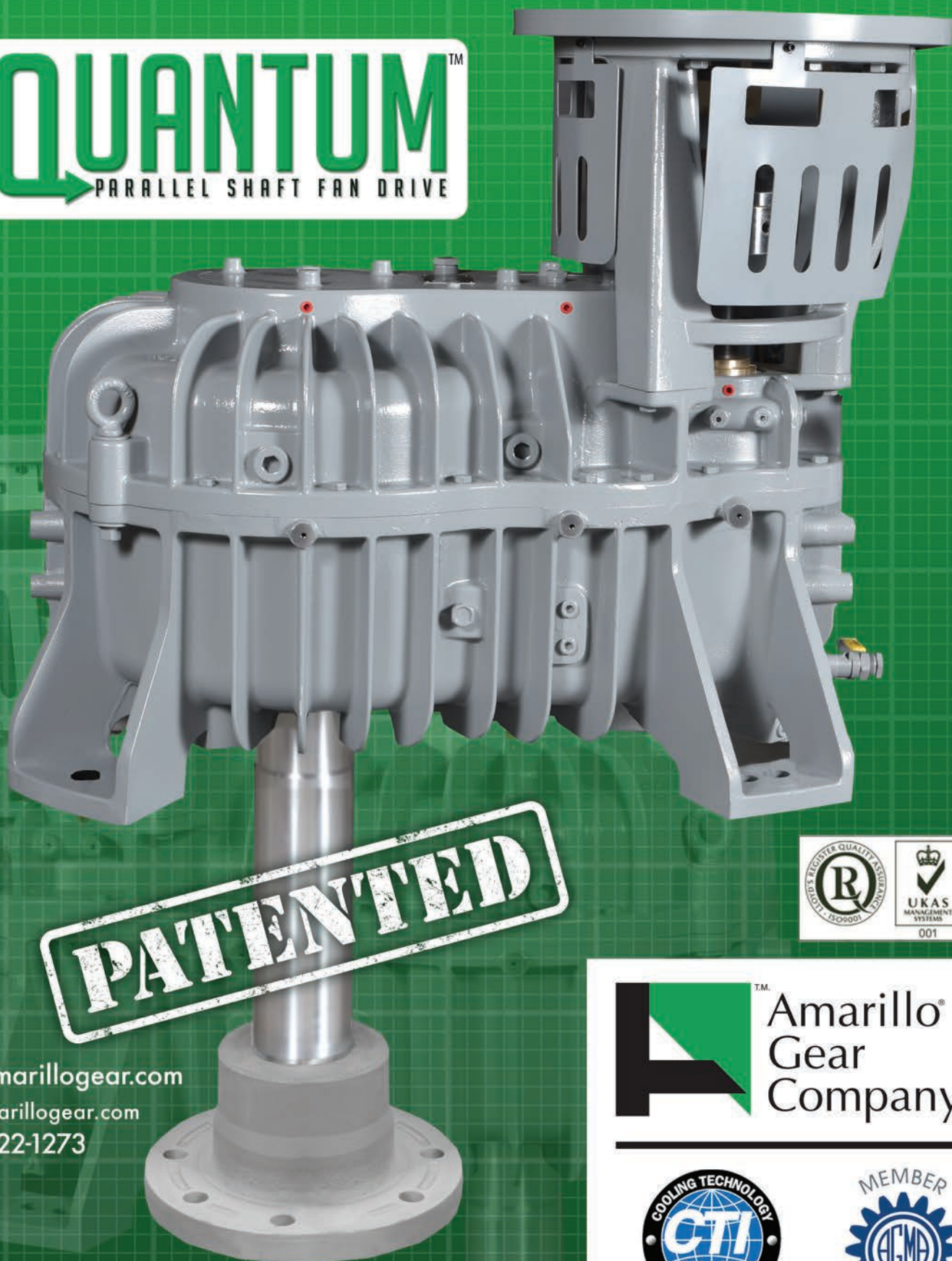

PATENTED



www.amarillogear.com
info@amarillogear.com
(806) 622-1273

 **Amarillo**TM
Gear
Company

 A Marmon/Berkshire Hathaway Company



QUANTUM PARALLEL SHAFT FAN DRIVE

by Amarillo Gear Company

The patented Quantum Parallel Shaft Fan Drive for dry cooling systems reflects a long history of quality workmanship and reliability. Amarillo Gear has been designing and manufacturing purpose designed gear drives since 1934, and the commitment to excellence continues today. One example of this commitment is the availability of complete noise and vibration testing, with all data taken under full power loading, up to 250 HP (186 kW) utilizing our in-house test lab.

Quantum Series Parallel Shaft Fan Drive Selection

Having a parallel shaft fan drive specifically designed for dry cooling systems means the process for selecting the correct fan drive model and ratio is simple. It is as easy as following the steps shown below. For unusual applications, or extreme operating conditions, please contact Amarillo Gear Company for help in making the best selection for your application.

Calculate the required ratio by dividing the motor speed (input) by the desired fan speed (output). Fan speed is determined by a combination of motor speed and gear ratio. All ratios are reducing and defined as the ratio of the input speed to output speed. Exact ratios are noted in Table 1. Special ratios may be available for specific applications. Please contact Amarillo Gear Company for more information.

TABLE I

HORSEPOWER RATINGS AT SERVICE FACTOR = 2.0				
Nominal Ratio	Motor Speed (rpm)	Models		
		Q400	Q500	Q600
14	Exact Ratio	13.86	C.F.	C.F.
	1750	210	C.F.	C.F.
	1500	181	C.F.	C.F.
	1200	146	C.F.	C.F.
15	Exact Ratio	15.18	C.F.	15.08
	1750	210	C.F.	365
	1500	181	C.F.	317
	1200	146	C.F.	259
16	Exact Ratio	16.19	C.F.	16.07
	1750	206	C.F.	348
	1500	178	C.F.	302
	1200	143	C.F.	247
17	Exact Ratio	16.97	C.F.	17.16
	1750	210	C.F.	330
	1500	181	C.F.	287
	1200	146	C.F.	235
18	Exact Ratio	17.73	18.22	18.23
	1750	206	265	336
	1500	178	229	290
	1200	143	185	234
19	Exact Ratio	18.82	19.27	19.37
	1750	200	254	317
	1500	172	220	273
	1200	139	179	221
20	Exact Ratio	19.83	19.78	19.75
	1750	206	250	295
	1500	178	217	257
	1200	143	177	208
21	Exact Ratio	21.05	20.82	20.63
	1750	200	265	298
	1500	172	229	257
	1200	139	185	207
22	Exact Ratio	C.F.	22.02	C.F.
	1750	C.F.	254	C.F.
	1500	C.F.	220	C.F.
	1200	C.F.	179	C.F.
22.5	Exact Ratio	C.F.	22.6	C.F.
	1750	C.F.	250	C.F.
	1500	C.F.	216	C.F.
	1200	C.F.	175	C.F.

KILOWATT RATINGS AT SERVICE FACTOR = 2.0				
Nominal Ratio	Motor Speed (rpm)	Models		
		Q400	Q500	Q600
14	Exact Ratio	13.86	C.F.	C.F.
	1750	157	C.F.	C.F.
	1500	135	C.F.	C.F.
	1200	109	C.F.	C.F.
15	Exact Ratio	15.18	C.F.	15.08
	1750	157	C.F.	272
	1500	135	C.F.	236
	1200	109	C.F.	193
16	Exact Ratio	16.19	C.F.	16.06
	1750	154	C.F.	260
	1500	133	C.F.	225
	1200	107	C.F.	184
17	Exact Ratio	16.97	C.F.	17.16
	1750	157	C.F.	246
	1500	135	C.F.	214
	1200	109	C.F.	175
18	Exact Ratio	17.73	18.22	18.23
	1750	154	198	251
	1500	133	171	216
	1200	107	138	174
19	Exact Ratio	19.82	19.27	19.37
	1750	149	189	236
	1500	128	164	204
	1200	104	133	165
20	Exact Ratio	19.83	19.78	19.75
	1750	154	186	220
	1500	133	162	192
	1200	107	132	155
21	Exact Ratio	21.05	20.82	20.63
	1750	149	198	222
	1500	128	171	192
	1200	104	138	154
22	Exact Ratio	C.F.	22.02	C.F.
	1750	C.F.	189	C.F.
	1500	C.F.	164	C.F.
	1200	C.F.	133	C.F.
22.5	Exact Ratio	C.F.	22.6	C.F.
	1750	C.F.	186	C.F.
	1500	C.F.	161	C.F.
	1200	C.F.	130	C.F.

*Once the required ratio is determined, always select a gear drive with a service rating that meets or exceeds the power rating of the input driver.

**Contact factory for unpublished ratios.

Next, select the fan drive from Table 1 that has a motor power rating, beside the nominal ratio column, that is equal or greater than the motor power at the motor speed. All ratings include an AGMA 2.0 service factor on motor nameplate power which is required by CTI STD 167 for long life and desired reliability. Ratings at intermediate speeds may be interpolated from the table. Contact the factory for recommendations when the electric motor speed is outside the table range.

Please contact Amarillo Gear for assistance in selection of the Quantum for Air-Cooled Condenser operation should extreme site conditions exist such as temperature, wind, sea air, etc.

Features of the Quantum.

DESIGN: The Quantum is specifically designed for the severe operating conditions encountered in an Air-Cooled Condenser. It is a purpose designed fan drive. This technology is specifically for an ACC to assure optimum reliability, long service life, and minimal maintenance. AGMA design and rating standards are used and the Quantum meets the CTI STD 167.

GEARING: Amarillo Gear has complete in-house gear design incorporating the latest manufacturing technology. This ability provides for 100% quality control. Helical gears are designed and manufactured from nickel alloy steel and are case hardened to ensure optimum tooth strength and precision ground to AGMA class Q11 quality level to provide low-noise, low vibration operation.

PATENTED DRY WELL: The Quantum is also designed with a proven and patented true dry well that requires no wear seals to contain the lubricant and keep contaminants out. And since the Quantum has a true dry well and all the bearings are oil lubricated, no oil or grease leaks will occur, unless the gearbox is overfilled with oil. This technology eliminates the need for greased bearings.

SEALS: The Quantum features a non-contact seal on the input shaft. Since it is a “no contact” design, it is designed to last the life of the gearbox with no required seal maintenance. The Quantum uses a true dry well, NO SEALS are required for the output shaft. Other gearbox designs still used in this application typically feature a wearable lip seal that requires frequent replacement and maintenance. The Quantum is designed to prevent the intrusion of water and other contaminants from all external sources.

BEARINGS: Bearings used in the Quantum are anti-friction, roller type, and sized to ensure long, reliable life. Bearing spans are maximized for spindle stability. The fan shaft thrust bearing is effectively sized to carry all loads imposed by the fan while maintaining at least 100,000 hours L10a life. Bearings on the input and intermediate shafts are sized to ensure a L10a life of no less than 50,000 hours. Bearings are only sourced from Tier 1 manufacturers such as Timken, SKF, NTN, etc.

GEAR CASE/HOUSING: The Quantum’s housings are designed using finite element analysis, and constructed to absorb internal and external loads. The Quantum’s design provides for strength and rigidity to ensure proper alignment of all gears and bearings when it is operating at rated speed and load. The Quantum gear case also feature fins for added surface area for heat dissipation and noise attenuation. The gear case is a split case design, with both case and cover doweled together to assure permanent and proper alignment of bearings and gears under load. The interior of the gear case features a sloped floor that permits complete drainage of oil when a change is required. All casting materials are ASTM A48 Class 30 gray iron with a tensile strength of 30,000 psi for effective damping of noise and vibration. The Quantum gear case design also allows for ease of service, should it ever be required.

SHAFTS: The input and output shafts for the Quantum are made from alloy steel and properly sized for the dynamics commonly seen in an Air-Cooled Condenser. These rigid shafts, installed in permanently aligned housings with maximized spans between bearings, guarantee precise alignment of the gears and bearings under load.

EFFICIENCY: The Quantum parallel shaft fan drive is tested to be 98% efficient under full load.

POWER RATINGS: The mechanical power rating of the Quantum fan drive is in accordance with applicable AGMA design standards which are sized and rated to AGMA 6013, and the catalog rating is based on a service factor of 2.0 based on electric motor nameplate power. The Quantum also complies with CTI-STD-167.

THERMAL CAPACITY: The Quantum does not require the use of an auxiliary fan for increased thermal capacity. The Quantum Parallel Shaft Fan Drive is designed to ensure that the thermal rating meets or exceeds the service (motor power) rating in Table 1 when the ambient temperature is 120°F or less. No Thermal calculations are required. For rare applications where the ambient temperature is above 120°F, contact Amarillo Gear for thermal ratings for your specific project conditions.

LUBRICATION: An internal positive displacement oil pump provides bidirectional lubrication. All plumbing is internal to the gear case (except where certain external options are specified), eliminating the risk of external oil leaks and handling damage. Each Quantum fan drive is equipped with an oil dip stick and oil level sight glass. Internal oil sump magnets are also a standard feature of every Quantum. All bearings in the Quantum are oil lubricated for lower maintenance and greater reliability. No periodic greasing of bearings is required on a Quantum parallel shaft fan drive, saving time, money, and ending oil and grease leaks. Oil lubricated bearings will avoid common problems associated with grease lubrication, such as over greasing, under greasing, improper grease selection, and difficulty in determining grease condition.

MOTOR STAND: Included with the Quantum is a rigidly designed support for the motor (motor stand) that will assure alignment of the coupling between the motor shaft and the Quantum input shaft. A guard is also supplied for the motor stand to prevent inadvertent contact with the rotating shafts and coupling, contain debris from a coupling failure, and provide an opening for visual inspection of the coupling, shafts, and non-contact bearing isolator seal.

CORROSION PROTECTION: Each Quantum fan drive features Carboline 890 epoxy paint finish. This durable finish is effective for most applications. However, if the ACC is located near or in a moist sea air environment, upgraded paint finishes are available.

TESTING: Each Quantum is spin tested prior to shipment and a complete conformity check is made. This ensures that Amarillo Gear supplies the product exactly as required and it will provide reliable service demanded by the owner.

WARRANTY: Each Quantum Parallel Shaft Fan Drive comes standard backed by Amarillo Gear's thirty-six (36) month warranty at no additional cost. To view this extensive warranty, please visit www.amarillogear.com

QUANTUMTM
PARALLEL SHAFT FAN DRIVE

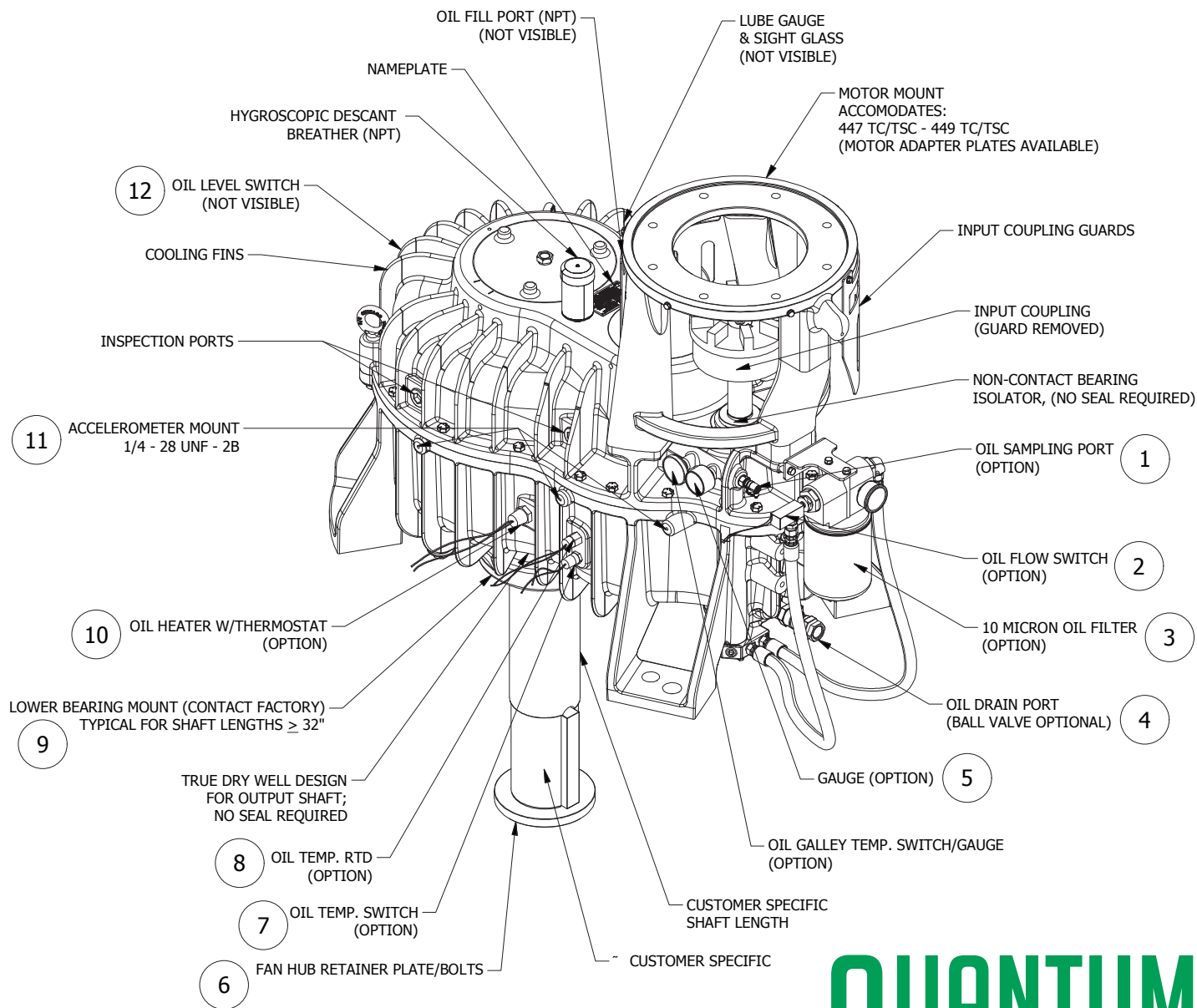

QUANTUM™

PARALLEL SHAFT FAN DRIVE

QUANTUM Options and Benefits		
ITEM	OPTION	BENEFIT
1	Oil Sample Port	Allows users to easily take oil samples without interruption of operation or removing any components.
2	Oil Flow Switch	Detects inadequate oil flow conditions through oil passage ways and triggers intended alarms and system shut offs.
3	Oil Filter	10 micron oil filter to increase oil cleanliness and improve the life of the gears and bearings.
4	Oil Drain Port w/ Ball Valve	Allows the integration of an oil drain system to be connected to the gearbox for quick and easy oil exchanges.
5	Oil Temperature Gauge	Allows visual monitoring of oil temperatures.
6	Retainer Plate / Bolts	Fan hub retainer plate designed for the customer application and verified for load and weight ratings.
7	Oil Temperature Switch	Detects high temperature conditions and triggers intended alarms and system shut offs.

8	RTD	Allows users to continuously monitor oil temperature as well as to set system alarms and notifications for specific temperature readings.
9	Extended Lower Bearing Housing	With the addition of an extended bearing, users are able to specify a longer output shaft and not affect gearbox or bearing life.
10	Oil Heater W/Thermostat	High surface area, low wattage heater with built in thermostat. Required for ACC's operated in ambient temperatures below synthetic oil pour points.
11	Spot face drill and taps	Gearbox comes standard with three 1/4"-28 UNF - 2B spot face drill and taps for vibration monitoring instruments.
12	Oil level switch	Detects low oil level conditions that may be detrimental to gearbox life and triggers intended alarms and system shut offs.
-	Non-Reverse	Reliable sprag design ensures that fans are unable to windmill in the reverse direction and cause damage upon startup or cause damage by reverse spinning.

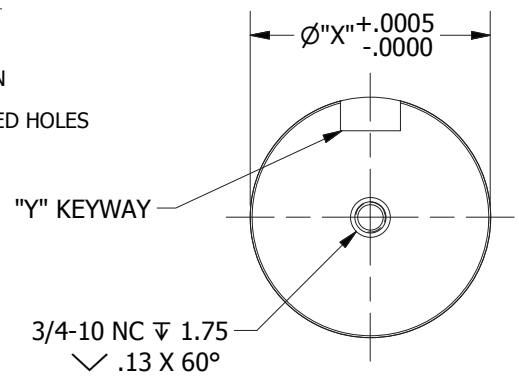
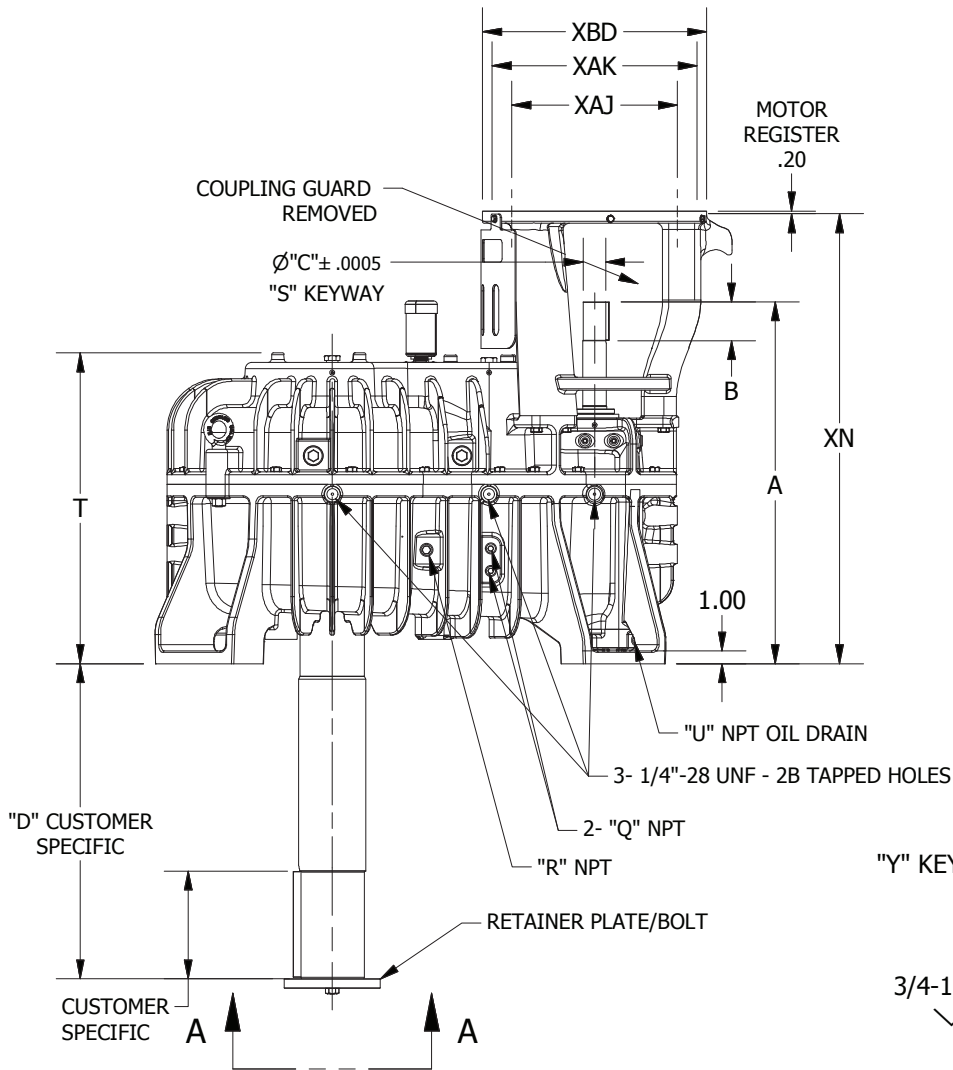
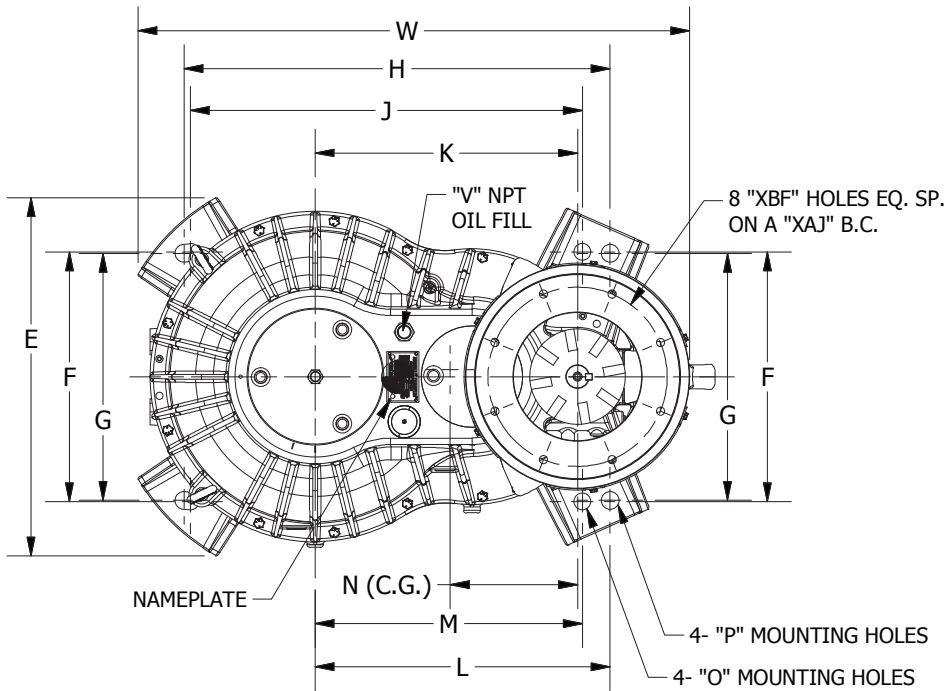

VIEW A-A
OUTPUT SHAFT DETAIL

*ALL DIMENSIONS ARE IN INCHES UNLESS OTHERWISE NOTED.

*RETAINER PLATE HOLES SUBJECT TO CHANGE BASED ON FAN HUB AND LOADING SPECIFICATIONS.

TABLE I - DIMENSIONS

MODEL	Q400	Q500	Q600
A	27.27	28.21	28.26
B	3.03	3.03	3.03
C	1.8135	1.8135	1.8135
D	C.S.	C.S.	C.S.
E	28.00	28.00	28.00
F	19.50	19.50	19.50
G	19.30	19.30	19.30
H	32.27	33.27	35.27
J	29.63	30.63	32.63
K	18.69	20.50	22.69
L	21.97	23.03	25.03
M	19.82	20.88	22.88
N *	12.48	13.91	15.83
O	1.31	1.31	1.31
P	1.42	1.42	1.42
Q	1/2	1/2	1/2
R	3/4	3/4	3/4
S	½ X ¼ X 3	½ X ¼ X 3	½ X ¼ X 3
T	22.51	23.53	24.86
U	1.00	1.00	1.00
V	1.00	1.00	1.00
W**	41.29	43.10	46.00
X	3.8740	4.9990	4.9990
Y	1 x ½	1¼	1¼
Oil Cap. (Gal)	8.50	10.00	11.50
Weight (lbs.)*	1650	2000	2320
Thrust Cap. (lbs.)	8,900	10,500	10,500

*Varies with output shaft length, and includes motor stand, oil, and motor coupling.

**Varies with the addition of optional components or motor adaptor plate.

*Dimensions and weights are subject to change without notice, Certified dimension prints must be requested.

*All dimensions in inches unless otherwise noted.

TABLE II - C FLANGE MOTOR MOUNT DIMENSIONS

MODEL	Q400		Q500		Q600	
FRAME	447/9 TS	447/9 T	447/9 TS	447/9 T	447/9 TS	447/9 T
XAJ	14.0	14.0	14.0	14.0	14.0	14.0
XAK	16.0	16.0	16.0	16.0	16.0	16.0
XBD	18.0	18.0	18.0	18.0	18.0	18.0
XBF	11/16	11/16	11/16	11/16	11/16	11/16
XN	A-6.795	A-8.317	A-6.886	A-8.408	A-6.894	A-8.416

*Contact factory for additional motor frame sizes.

TABLE III - A WEIGHTED SOUND POWER (dBA)

FREQUENCY (Hz)	Q400	Q500	Q600
63	C.F.	83.0	C.F.
125	C.F.	73.0	C.F.
250	C.F.	68.0	C.F.
500	C.F.	89.0	C.F.
1000	C.F.	81.0	C.F.
2000	C.F.	81.0	C.F.
4000	C.F.	75.0	C.F.
8000	C.F.	66.0	C.F.
Overall Max	C.F.	89.0	C.F.

TABLE IV - SHIPPING WEIGHTS AND DIMENSIONS

MODEL	Weight with Export Crate (lbs.)*	Export Crate Dimensions (in)		
		Length	Width	Height**
Q400	2294(1041kg.)	55(1.4m)	44(1.1m)	88(2.2m)
Q500	2644(1199kg.)	55(1.4m)	44(1.1m)	88(2.2m)
Q600	2964(1345kg.)	55(1.4m)	44(1.1m)	88(2.2m)

*Weight varies with output shaft length.

**Height varies with output shaft length, above value represents shaft length of 32"

*Dimensions and weights are subject to change without notice, Certified dimension prints must be requested.



Reliable & Low Maintenance

Who to Contact?

For general inquiries, please contact us:

Phone: 806 622 1273

Fax: 806 622 3258

Email: info@amarillogear.com

Amarillo Gear Company LLC

2401 Sundown Lane

Amarillo, Texas 79118

www.amarillogear.com

